

VorCone MVC

Технические характеристики

По вопросам продаж и поддержки обращайтесь:

Алматы (7273)495-231	Казань (843)206-01-48	Новокузнецк (3843)20-46-81	Смоленск (4812)29-41-54
Архангельск (8182)63-90-72	Калининград (4012)72-03-81	Новосибирск (383)227-86-73	Сочи (862)225-72-31
Астрахань (8512)99-46-04	Калуга (4842)92-23-67	Омск (3812)21-46-40	Ставрополь (8652)20-65-13
Барнаул (3852)73-04-60	Кемерово (3842)65-04-62	Орел (4862)44-53-42	Сургут (3462)77-98-35
Белгород (4722)40-23-64	Киров (8332)68-02-04	Оренбург (3532)37-68-04	Тверь (4822)63-31-35
Брянск (4832)59-03-52	Краснодар (861)203-40-90	Пенза (8412)22-31-16	Томск (3822)98-41-53
Владивосток (423)249-28-31	Красноярск (391)204-63-61	Пермь (342)205-81-47	Тула (4872)74-02-29
Волгоград (844)278-03-48	Курск (4712)77-13-04	Ростов-на-Дону (863)308-18-15	Тюмень (3452)66-21-18
Вологда (8172)26-41-59	Липецк (4742)52-20-81	Рязань (4912)46-61-64	Ульяновск (8422)24-23-59
Воронеж (473)204-51-73	Магнитогорск (3519)55-03-13	Самара (846)206-03-16	Уфа (347)229-48-12
Екатеринбург (343)384-55-89	Москва (495)268-04-70	Санкт-Петербург (812)309-46-40	Хабаровск (4212)92-98-04
Иваново (4932)77-34-06	Мурманск (8152)59-64-93	Саратов (845)249-38-78	Челябинск (351)202-03-61
Ижевск (3412)26-03-58	Набережные Челны (8552)20-53-41	Севастополь (8692)22-31-93	Череповец (8202)49-02-64
Иркутск (395)279-98-46	Нижний Новгород (831)429-08-12	Симферополь (3652)67-13-56	Ярославль (4852)69-52-93
Россия (495)268-04-70	Киргизия (996)312-96-26-47	Казахстан (7172)727-132	

VorCone™ Flowmeter

Model MVC Mass VorCone Meter

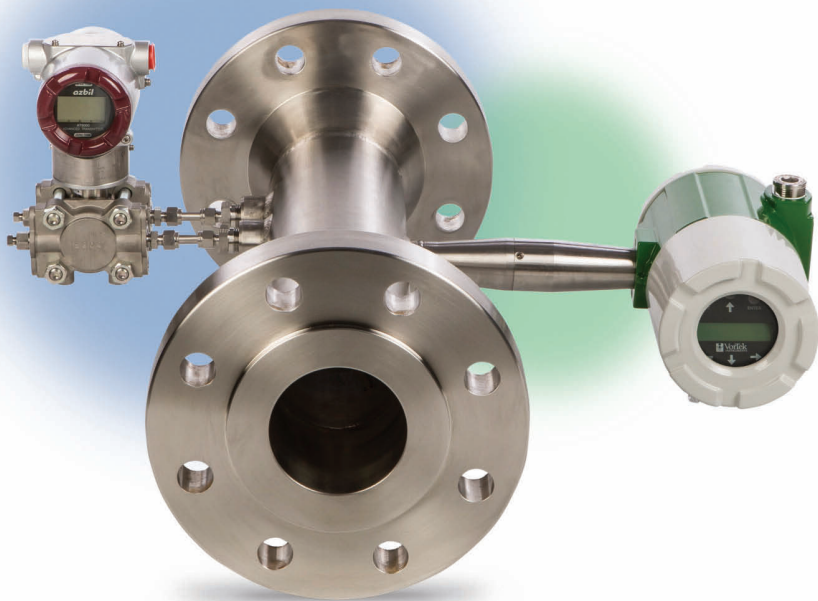

VorTek Instruments' VorCone™ flowmeters utilize two different flow meter technologies in combination; vortex and differential pressure. The design has blended the two separate flow metering principles into one hybrid system where the two meters complement each other's performance. This combination allows for the prediction of the fluid density, volumetric flow rate and mass flow rate without any fluid density information being required from an external source.

This ability to measure fluid density allows the meter to provide several valuable outputs. The VorCone meter can calculate the density of changing gas mixtures. For example, natural gas is typically a composition of many different gases which can vary over time and vary by application. In saturated steam service, the meter produces a reliable steam quality (dryness) measurement, and steam mass flow rate reading. In wet natural gas service, the meter is able to provide a reliable liquid loading measurement, and gas mass flow rate reading. These are a few examples of the unique capabilities of the VorCone meter.

With the addition of two differential pressure transmitters, advanced diagnostic software (DP Health Check™) continually monitors and verifies the meter's performance. The VorCone product line is available with a wide range of options and meter configurations to meet your specific application requirements.

VorCone™ Advantage:

Single phase service

- Measures fluid density, volumetric flow rate and mass flow rate without any density information being required from an external source
- Able to calculate the density of changing gas mixtures. For example, natural gas is typically a composition of many different gases which can vary over time and vary by application
- With a VTP model, VorCone is able to compare calculated density against predicted density to ensure the accuracy of the density measurement
- Energy Monitoring. Ability to compute and output energy consumption with select fluids. Steam, water, and heat transfer fluids
- Advanced diagnostic software (DP Health Check™), is able to continually monitor and verify the meter's cone element health and confirm output uncertainty

Saturated steam service

- Provides a total mass flow measurement of steam and water mixture
- Provides a reliable steam quality (dryness) measurement
- More cost effective than current steam quality (dryness) meters
- A combination of the two most proven technologies for steam metering; vortex and differential pressure cone metering
- Energy Monitoring. Ability to accurately compute and output energy consumption based on steam quality (dryness)
- With on board data logging, you can track and trend steam quality (dryness)

Wet gas service

- Provides a reliable liquid loading measurement
- Knowing the liquid loading, the VorCone meter provides an accurate corrected gas flow measurement
- With on board data logging, you can track and trend liquid loading

VorCone Principle of Operation

With a single phase flow, a vortex meter measures the actual volumetric flow rate (Q). The vortex meter reads the vortex shedding frequency off the bluff body (f) and relates it via the meter factor (K) to the volume flowrate (Q), see equation 1. This volumetric flow rate measurement is density (ρ) insensitive.

$$(1) \quad Q = \frac{f}{K}$$

With a single phase flow, a differential pressure (DP) flow meter measures the volumetric flowrate once the density is supplied from an external source. The DP meter volume flowrate calculation is density (ρ) sensitive. Equation 2 shows the cone DP meter volumetric flow equation, where E and At are fixed geometry terms, Cd is the discharge coefficient, and ΔP_t is the cone meter DP primary signal.

$$(2) \quad Q = EA_c C_d \sqrt{\frac{2\Delta P_t}{\rho}}$$

As described by Boden in 1956, if a density sensitive meter (cone DP meter) is cross referenced with a density insensitive meter (vortex meter) the density can be derived internally by the system, i.e. see equation 3.

$$(3) \quad \rho = (2\Delta P) \left(\frac{K_v EA_c \epsilon C_d}{f} \right)^2$$

The VorCone mass flowrate calculation is now calculated via equation 4, where the vortex meter volumetric flow prediction (Q) and this internal density prediction (ρ) are used. No external density measurement is required.

$$(4) \quad m = \rho Q$$

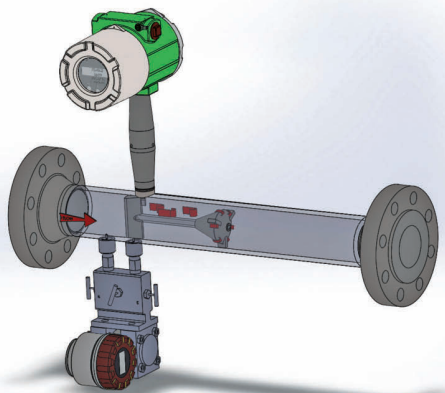

*For illustrative purposes only.
Not representative of a correct installation orientation.*

Suggested Configurations Per Application

Single phase service

- Able to measure fluid density, volumetric flow rate and mass flow rate without any density information being required from an external source.
- Able to calculate the density of changing gas mixtures.

MINIMUM MEASUREMENT VARIABLES REQUIRED: VELOCITY

*Models with velocity, temperature, and pressure variables can compare predicted and calculated density to ensure density accuracy.

All acceptable configurations (Feature 1: Configuration Options)

- V -Velocity sensor
- VT -Velocity and Temperature Sensors
- VTP - Velocity, Temperature and Pressure Sensors*
- VTEP - Velocity, Temperature and External 4-20mA Input (T or P)*

- VETEP - Velocity, External RTD Temperature Input, External 4-20mA Input*
- VT-EM - Energy output options
- VTP-EM - Energy options with Pressure Sensor*
- VTEP-EM - Velocity, Temperature and External 4-20mA Input*
- VETEP-EM - Velocity, External RTD Temperature Input, External 4-20mA Input*

Saturated steam service

- Provides a reliable steam quality (dryness) measurement, and steam total mass flow rate reading (steam & water mixture).

MINIMUM MEASUREMENT VARIABLES REQUIRED:
VELOCITY AND TEMPERATURE

All acceptable configurations (Feature 1: Configuration Options)

- VT -Velocity and Temperature Sensors
- VTP -Velocity, Temperature and Pressure Sensors
- VTEP -Velocity, Temperature and External 4-20mA Input (T or P)
- VETEP -Velocity, External RTD Temperature Input, External 4-20mA Input (T or P)
- VT-EM -Energy output options
- VTP-EM -Energy options with Pressure Sensor
- VTEP-EM -Velocity, Temperature and External 4-20mA Input (T or P)
- VETEP-EM -Velocity, External RTD Temperature Input, External 4-20mA Input (T or P)

Wet gas service

- Provides a reliable liquid loading measurement, and gas mass flow rate reading.

MINIMUM MEASUREMENT VARIABLES REQUIRED:
VELOCITY, TEMPERATURE AND PRESSURE

All acceptable configurations (Feature 1: Configuration Options)

- VTP -Velocity, Temperature and Pressure Sensors
- VTEP -Velocity, Temperature and External 4-20mA Input (T or P)
- VETEP -Velocity, External RTD Temperature Input, External 4-20mA Input (T or P)
- VTP-EM -Energy options with Pressure Sensor
- VTEP-EM -Velocity, Temperature and External 4-20mA Input (T or P)
- VETEP-EM -Velocity, External RTD Temperature Input, External 4-20mA Input (T or P)

Onboard data logging

All acceptable configurations (Feature 7: Input power)

- DCHPOE -12-28 VDC or Power over Ethernet, 5 Watts maximum, required on 1AMIP, 1ABIP, 3AMIP, 3ABIP

All acceptable configurations (Feature 8: Output)

- 1AMIP -One analog output (4-20 mA), one alarm, one pulse, MODBUS TCP/IP Communication Protocol, DCHPOE ONLY
- 1ABIP -One analog output (4-20 mA), one alarm, one pulse, BACnet/IP Communication Protocol, DCHPOE ONLY
- 3AMIP -Three analog outputs (4-20 mA), three alarms, one pulse, MODBUS TCP/IP (VT, VTP only), DCHPOE ONLY
- 3ABIP -Three analog outputs (4-20 mA), three alarms, one pulse, BACnet/IP (VT, VTP only), DCHPOE ONLY

Performance Specifications

Accuracy

Multiparameter VorCone Meter			
Process Variables	Liquids	Dry Gas/ Superheated Steam	Wet Gas/ Saturated Steam
Volumetric Flow Rate	± .7% of Rate	± 1% of Rate	± 3% of Rate
Mass Flow Rate	± 1% of Rate	± 1% of Rate	± 3% of Rate
Temperature	± 2°F (± 1°C)	± 2°F (± 1°C)	± 2°F (± 1°C)
Pressure	± .3% of Full Scale	± .3% of Full Scale	± .3% of Full Scale
Calculated Density**	± .3% of Reading	± .5% of Reading	N/A
Predicted Density***	± .75% of Reading	± 1.5% of Reading	± 4% of Reading*
Saturated Steam/Wet Gas Quality	N/A	N/A	± 2% of Full Scale*

* Depending on percentage of liquid content & velocity. For wet gas, Lockhart Martinelli parameter less than 0.15 (XLM < 0.15) is recommended. For saturated steam, steam dryness fraction between 0.4 to 1.00 is recommended. Measurement uncertainty can increase if used outside of these recommendations.

** Calculated density is derived from equations of state and a known fluid temperature & pressure.

*** Predicted density is a function inherent to the combined technologies of vortex and differential pressure flow metering. It denotes the VorCone meter density output.

The Lockhart–Martinelli parameter expresses the liquid fraction of a flowing fluid.

Repeatability

Mass Flow Rate ± .2% of rate
 Volumetric Flow Rate ± .1% of rate
 Temperature ± 2°F (± .1°C)
 Pressure ± .05% of full scale
 Calculated Density ± .1% of reading

Stability Over 12 Months

Mass Flow Rate ± .2% of rate
 Volumetric Flow Rate ± negligible
 Temperature ± .9°F (± .5°C)
 Pressure ± .1% of full scale
 Calculated Density ± .1% of reading

Response Time

Adjustable from 1 to 100 seconds

Operating Specifications

Any gas, liquid or steam compatible with 316L stainless steel, C276 hastelloy or A105 carbon steel.

Process and Ambient Temperature

Process Standard Temperature (code ST): -330 to 500°F (-200 to 260°C)

Process High Temperature (code HT): to 750°F (400°C)

Ambient Operating: -40 to 140°F (-40 to 60°C)

Ambient Storage: -40 to 185°F (-40 to 85°C)

Pressure Transducer Ratings			
Full Scale Operating Pressure		Max. Over-Range Pressure	
psia	bara	psia	bara
30	2	60	4
100	7	200	14
300	20	300	40
500	35	1000	70
1500	100	2750	175

Power Requirements

DCL option: 12-36 VDC, 25mA, 1W max, loop powered (single output)

DCH option: 12-36 VDC, 300mA, 9W max, (multiple outputs)

AC option: 100-240 VAC, 50/60Hz line power, 5W (multiple outputs)

DCHPOE option: 12-28 VDC or Power over Ethernet, 5W maximum (multiple outputs)

Display

Alphanumeric 2 line x 16 character LCD digital display

Six pushbuttons for full field configuration

Pushbuttons can be operated with magnetic wand without removal of enclosure covers

Display can be mounted in 90° intervals for better viewing

Output Signals

Analog: 4-20 mA

Alarm: Solid state relay, 40 VDC

Totalizer Pulse: 50 millisecond pulse, 40 VDC

Volumetric or Loop Powered Mass: One analog, one totalizer pulse, HART

Multivariable option: Up to three analog signals, three alarms, one totalizer pulse, HART

Multivariable option: Modbus, Ethernet, or BACnet process monitoring

Physical Specifications

Wetted Materials

Standard 316L Stainless Steel, plus

- Optional Carbon Steel or Hastelloy C
- DuPont Teflon® based thread sealant on models with pressure transducer



Approvals—Pending

FM, FMC CLASS I, DIV. 1, GROUPS B,C,D
 CLASS II/III, DIV. 1, GROUPS E,F,G
 Type 4X and IP66, T6, Ta = -40 to 60°C

ATEX II 2 G Ex d IIB + H2 T6
 II 2 D EX tD A21 IP66 T85°C, Ta = -40 to 60°C

IECEX Ex d IIB + H2 T6
 Ex tD A21 IP66 T85°C, Ta = -40 to 60°C

Sizing Considerations

Condition	Pipe Diameters, D	
	Upstream	Downstream
One 90° elbow before meter	10D	5D
Two 90° elbows before meter	15D	5D
Two 90° elbows before meter, out of plane	30D	10D
Reduction before meter	10D	5D
Expansion before meter	20D	5D
Partially open valve	30D	10D

Velocity Range

Maximum velocity, liquid: 30 feet/sec (9 meters/second)

Minimum velocity, liquid: 1 foot/sec (.3 meters/second)

Maximum velocity, gas or steam: See Table Below

Minimum velocity, gas or steam feet/sec (meters/second):

$$\sqrt{\frac{5}{\text{density (Lb/ft}^3)}} \quad \sqrt{\frac{6.1}{\text{density (kg/m}^3)}}$$

Pressure Drop Equations

$\Delta P = 0.00044 p V^2$ English Units (ΔP in psi, p in lb/ft^3 , V in ft/sec)

$\Delta P = 0.00002 p V^2$ Metric Units (ΔP in bar, p in kg/m^3 , V in m/sec)

Water Minimum and Maximum Flow Rates							
Rate	Nominal Pipe Size (in)						
	2	3	4	6	8	10	12
GPM min	9.2	21	36	81	142	224	317
GPM max	276	618	1076	2437	4270	6715	9501
Rate	Nominal Pipe Size (mm)						
	50	80	100	150	200	250	300
M ³ /hr min	2.1	4.7	8.1	18	32	51	72
M ³ /hr Max	63	140	244	554	970	1525	2158

Gas or Steam Max Velocity							
Rate	Nominal Pipe Size (in)						
	2	3	4	6	8	10	12
FT/SEC Max	300	300	300	300	300	300	300
Rate	Nominal Pipe Size (mm)						
	50	80	100	150	200	250	300
M/SEC Max	90	90	90	90	90	90	90

Advanced Diagnostics

VorCone Meter DP Cone Meter Advanced Diagnostics—DP Health Check™

DP Health Check is a comprehensive verification system for Differential Pressure (DP) meters. The VorCone meter's cone DP meter sub-system can operate with DP Health Check. Utilizing a third pressure port downstream of the cone and reading three DPs, DP Health Check analyses not just the traditional single DP reading, but the entire pressure field. The additional information expands the capability of the cone meter, offering a full diagnostic suite. DP Health Check creates a smart cone meter allowing for condition based maintenance operations.

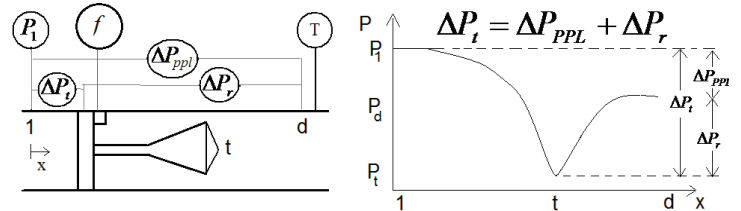

Fig 1. DP Health Check™ Ready Cone DP Meter and Associated Pressure Field

DP Health Check creates seven diagnostic checks, i.e. one DP integrity check, three separate inter-comparable flowrate predictions, and three DP ratios comparable with the baselines. The HMI (human-machine interface) is designed for simplicity: the seven diagnostics are plotted as four points on a graph with a 1x1 box. All points inside the box shows the meter is functioning normally (see Fig 2). Any points outside the box shows a potential metering issue. Figs. 3 and 4 show response to varying saturated steam quality and single phase DPt reading error respectively. Pattern recognition technology allows the source of the problem to be directly identified

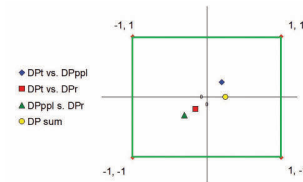

Fig 2. Display for Correctly Operating Meter

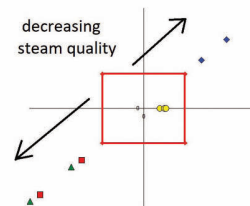

Fig 3. Display for Varying Quality Saturated Steam Flow

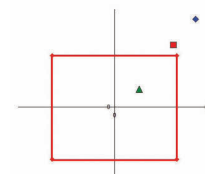

Fig 4. Display for Drifting DP Transmitter

Typical Saturated Steam Minimum and Maximum Flow Rates (lb/hr)							
Nominal Pipe Size (in)							
Pressure	2	3	4	6	8	10	12
5 psig	82	183	318	722	1264	1988	2813
	1087	2431	4231	9594	16806	26429	37395
100 psig	187	419	728	1652	2893	4550	6438
	5690	12729	22156	50233	87998	138386	195803
200 psig	253	565	983	2229	3905	6141	8689
	10365	23184	40354	91494	160279	252055	356635
300 psig	304	680	1184	2685	4704	7397	10466
	15040	33642	58556	132763	232575	365747	517499
400 psig	349	780	1358	3079	5393	8481	12000
	19770	44222	76971	174516	305717	480771	680247
500 psig	389	870	1514	3433	6014	9457	13381
	24582	54987	95710	217001	380148	597812	845850

Typical Saturated Steam Minimum and Maximum Flow Rates (kg/hr)							
Nominal Pipe Size (mm)							
Pressure	50	80	100	150	200	250	300
0 barg	32	72	126	286	500	786	1113
	375	838	1459	3309	5797	9116	12898
5 barg	75	167	290	658	1153	1813	2565
	1992	4455	7754	17581	30799	48434	68530
10 barg	99	222	387	877	1537	2417	3419
	3539	7915	13777	31237	54720	86053	121758
15 barg	119	266	463	1050	1840	2893	4094
	5073	11347	19750	44779	78444	123360	174543
20 barg	136	304	529	1199	2100	3303	4673
	6611	14787	25738	58355	102226	160761	227463
30 barg	165	369	642	1455	2548	4007	5669
	9729	21763	37880	85884	150451	236599	334766

Typical Air Minimum and Maximum Flow Rates (SCFM) Air at Standard Process Conditions 70°F, 14.6959 PSIA							
Nominal Pipe Size (in)							
Pressure	2	3	4	6	8	10	12
0 psig	22	50	87	198	347	546	773
	369	826	1437	3258	5708	8976	12701
100 psig	63	141	245	555	972	1529	2163
	2890	6466	11254	25515	44698	70292	99456
200 psig	86	193	335	761	1332	2095	2965
	5427	12140	21131	47911	83931	131895	186752
300 psig	104	234	407	922	1615	2540	3594
	7978	17847	31064	70431	123375	194025	274529
400 psig	120	269	467	1060	1857	2920	4132
	10542	23580	41043	93057	163000	256358	362724
500 psig	134	300	521	1182	2071	3257	4608
	13115	28034	51063	115775	203000	318941	451272

Typical Air Minimum and Maximum Flow Rates (nm³/hr) Air at Standard conditions of 20°C, 1.0133 BARA							
Nominal Pipe Size (mm)							
Pressure	50	80	100	150	200	250	300
0 barg	36	79	138	313	549	863	1221
	584	1307	2275	5157	9034	14207	20102
5 barg	87	194	337	764	1339	2105	2979
	3476	7775	13533	30682	53749	84525	119596
10 barg	117	262	457	1035	1814	2853	4036
	6381	14273	24844	56329	98676	155178	219563
15 barg	142	317	551	1250	2190	3444	4873
	9299	20801	36205	82087	143801	297386	319968
20 barg	162	363	632	1434	2511	3949	5588
	12229	27354	47612	107949	189105	297386	420775
30 barg	198	442	770	1745	3057	4807	6801
	18119	40529	70544	159942	280187	440621	623439

Turndown

Turndown is application dependent.

Dimensional Outline: MVC Mass VorCone Meter

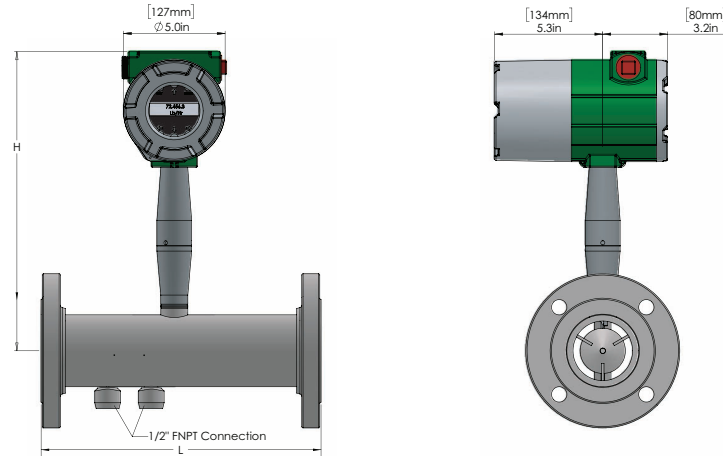

Flow Meter Nominal Size	Dimensions			Weight			
	L (ANSI 150/300/600)	L (ANSI 900)	H	ANSI 150 (PN16)	ANSI 300 (PN 40)	ANSI 600 (PN 63)	ANSI 900 (PN 160)
2 inch (50 mm)	11.5 in (293 mm)	19.6 in (498 mm)	14.0 in (356 mm)	23.5 LB (10.7 kg)	27.1 LB (12.3 kg)	30.4 LB (13.8 kg)	63.7 LB (28.9 kg)
3 inch (80 mm)	13.6 in (346 mm)	21.6 in (549 mm)	14.6 in (371 mm)	39.5 LB (18.0 kg)	48.2 LB (21.9 kg)	53.5 LB (24.3 kg)	84.3 LB (38.3 kg)
4 inch (100 mm)	16.8 in (427 mm)	25.8 in (655 mm)	15.1 in (384 mm)	57.5 LB (26.1 kg)	76.7 LB (34.8 kg)	98.7 LB (44.8 kg)	136.1 LB (61.8 kg)
6 inch (150 mm)	21.5 in (546 mm)	32.5 in (826 mm)	16.2 in (411 mm)	106.2 LB (48.2 kg)	143.0 LB (64.9 kg)	201.7 LB (91.5 kg)	296.4 LB (134.5 kg)
8 inch (200 mm)	26.4 in (671 mm)	39.2 in (996 mm)	17.2 in (437 mm)	188.7 LB (85.6 kg)	242.7 LB (110.1 kg)	329.0 LB (149.3 kg)	516.5 LB (234.3 kg)
10 inch (250 mm)	33.7 in (856 mm)	48.2 in (1224 mm)	18.2 in (462 mm)	322.5 LB (146.3 kg)	401.7 LB (182.3 kg)	564.0 LB (255.9 kg)	815.7 LB (370.0 kg)
12 inch (300 mm)	39.6 in (1006 mm)	55.3 in (1405 mm)	19.2 in (488 mm)	524.1 LB (237.8 kg)	631 LB (286.3 kg)	771.5 LB (350.0 kg)	1167.3 LB (529.5 kg)

Add 11 lb (5 KG) for remote electronics Add 8 lb (3.6 KG) for Azbil DP transmitter Weights and dimensions for reference only

Spool Piece Nominal Size	Weight					
	L (ANSI 150/300/600)	L (ANSI 900)	ANSI 150 (PN16)	ANSI 300 (PN 40)	ANSI 600 (PN 63)	ANSI 900 (PN 160)
2 inch (50 mm)	6.3 in (160 mm)	14.4 in (366 mm)	12.0 LB (5.5 kg)	15.6 LB (7.1 kg)	18.9 LB (8.6 kg)	52.1 LB (23.7 kg)
3 inch (80 mm)	9.0 in (229 mm)	16.9 in (429 mm)	25.0 LB (11.4 kg)	33.7 LB (15.3 kg)	38.9 LB (17.7 kg)	64.5 LB (29.3 kg)
4 inch (100 mm)	10.6 in (269 mm)	19.6 in (498 mm)	36.9 LB (16.8 kg)	56 LB (25.5 kg)	78.1 LB (35.5 kg)	115.1 LB (52.3 kg)
6 inch (150 mm)	14.7 in (373 mm)	25.8 in (655 mm)	68.1 LB (30.9 kg)	104.8 LB (47.6 kg)	163.5 LB (74.2 kg)	257.2 LB (116.7 kg)
8 inch (200 mm)	19.4 in (493 mm)	32.2 in (818 mm)	123.9 LB (56.2 kg)	177.9 LB (80.7 kg)	264.2 LB (119.9 kg)	449.9 LB (204.1 kg)
10 inch (250 mm)	24.1 in (612 mm)	38.6 in (980 mm)	202.5 LB (91.9 kg)	281.7 LB (127.8 kg)	444.0 LB (201.4 kg)	691.3 LB (313.6 kg)
12 inch (300 mm)	28.5 in (724 mm)	44.2 in (1123 mm)	326.8 LB (148.3 kg)	433.7 LB (196.8 kg)	574.2 LB (260.5 kg)	964.3 LB (437.4 kg)

Optional – Spool Piece for DP Health Check

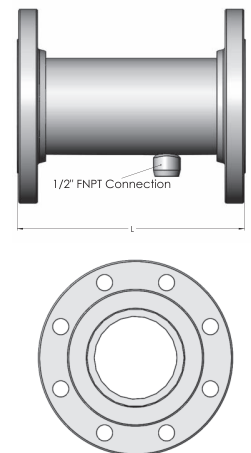

Weights and dimensions for reference only

Dimensional Outline: Remote Electronics Option

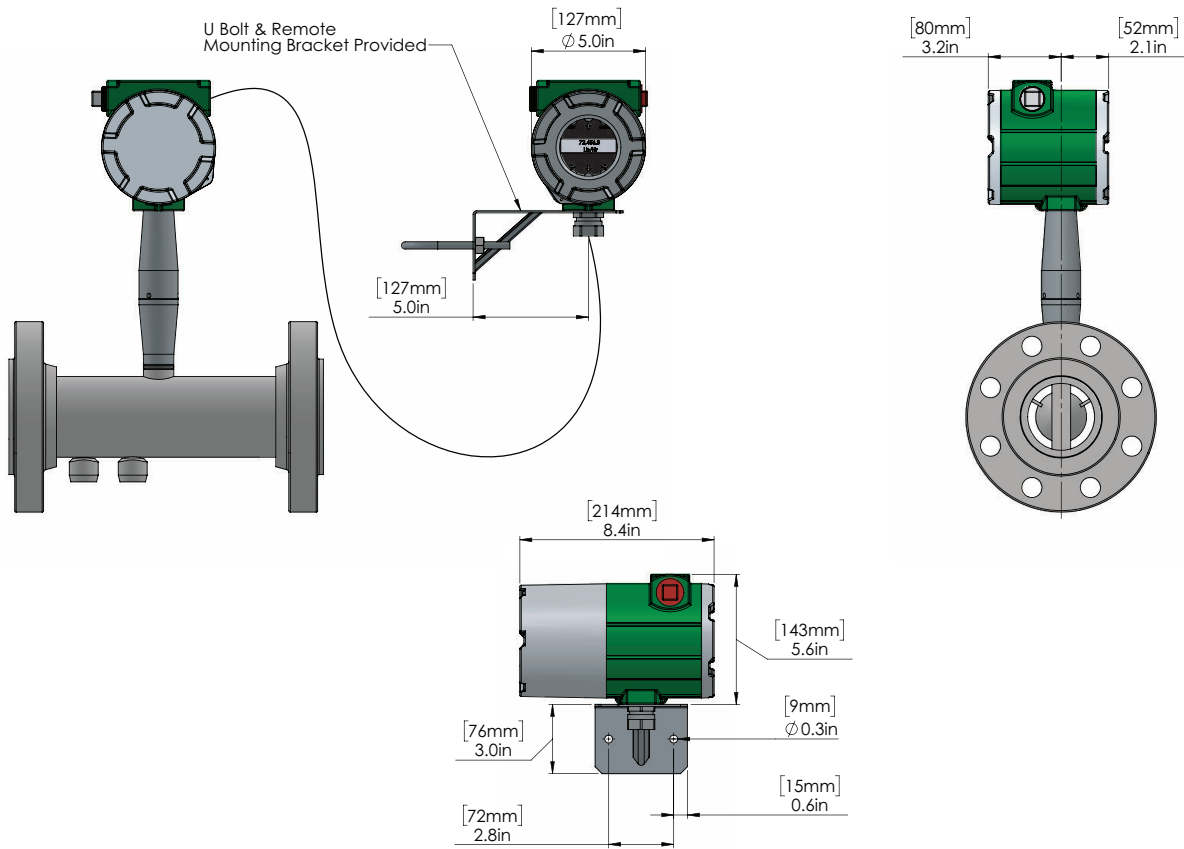

Model Number Information - Model MVC Mass VorCone Meter

Parent Number Code

MVC Model MVC Mass VorCone Meter	MVCR	Model MVC Mass VorCone Reducing Meter
---	-------------	---------------------------------------

Feature 1: Configuration Options (See "Suggested Configurations Per Application" on page 2)

<p>V Velocity sensor</p> <p>VT Velocity and Temperature Sensors</p> <p>VTP Velocity, Temperature and Pressure Sensors</p> <p>VTEP Velocity, Temperature and External 4-20mA Input (T or P)</p>	<p>VETEP Velocity, External RTD Temperature Input, External 4-20mA Input (T or P)</p> <p>VT-EM Energy output options</p> <p>VTP-EM Energy options with Pressure Sensor</p> <p>VTEP-EM Velocity, Temperature and External 4-20mA Input (T or P)</p> <p>VTEP-EM Velocity, External RTD Temperature Input, External 4-20mA Input (T or P)</p>
--	---

Feature 2: Flow Body (MVC)

16 2-inch Nominal Bore (50mm)

24 3-inch Nominal Bore (80mm)

32 4-inch Nominal Bore (100mm)

48 6-inch Nominal Bore (150mm)

64 8-inch Nominal Bore (200mm)

80 10-inch Nominal Bore (250mm)

96 12-inch Nominal Bore (300mm)

Reducing Flow Body (MCVR)

3-inch by 2-inch Reducing Meter (50mm)

4-inch by 3-inch Reducing Meter (80mm)

6-inch by 4-inch Reducing Meter (100mm)

8-inch by 6-inch Reducing Meter (150mm)

10-inch by 8-inch Reducing Meter (200mm)

12-inch by 10-inch Reducing meter (250mm)

Feature 3: Meter Body Material

C Carbon Steel	S 316 Stainless Steel	H Hastelloy
-----------------------	------------------------------	--------------------

Model Number Information - Model MVC Mass VorCone Meter (continued)

Feature 4: Process Connection

150	ANSI 150# Flange	16	PN 16
300	ANSI 300# Flange	40	PN 40
600	ANSI 600# Flange	64	PN 64
900	ANSI 900# Flange	100	PN 100
*	Consult factory if other process connections are required		

Feature 5: Electronics Enclosure

L	NEMA 4X IP66 Enclosure
R ()	Remote Electronics NEMA 4X, IP66, Specify cable length in parentheses

Feature 6: Display Options

DD	Digital Display and Programming Buttons
-----------	---

Feature 7: Input Power

DCL	12-36 VDC, 25mA, 1W max. required on loop powered meters (Unable to power differential pressure transmitter with this option), 1AHL only
DCH	12-36 VDC, 300mA, 9W max. (Able to power differential pressure transmitter if wired in series with an adequate power supply) - use with 1AH, 1AM, 3AH, 3AM
DCHPOE	12-28 VDC or Power over Ethernet, 5 Watts maximum, required on 1AMIP, 1ABIP, 3AMIP, 3ABIP
AC	100-240 VAC, 50/60 Hz line power, 5W max. (Able to power differential pressure transmitter with DC power output) - use with 1AH, 1AM, 3AH, 3AM

Feature 8: Output

1AHL	Loop powered option - one analog output (4-20 mA), one scaled frequency, one pulse, HART, DCL input power only
1AH	One analog output (4-20 mA), one alarm, one pulse, HART Communication Protocol, DCH or AC option only *
1AM	One analog output (4-20 mA), one alarm, one pulse, MODBUS RTU Communication Protocol, DCH or AC option only *
1AMIP	One analog output (4-20 mA), one alarm, one pulse, MODBUS TCP/IP Communication Protocol, DCHPOE ONLY*
1AB	One analog output (4-20 mA), one alarm, one pulse, BACnet MS/TP Communication Protocol, DCH or AC option only *
1ABIP	One analog output (4-20 mA), one alarm, one pulse, BACnet/IP Communication Protocol, DCHPOE ONLY*
3AH	Three analog outputs (4-20 mA), three alarms, one pulse, HART (VT,VTP only), DCH or AC option only *
3AM	Three analog outputs (4-20 mA), three alarms, one pulse, MODBUS RTU (VT,VTP only), DCH or AC option only *
3AMIP	Three analog outputs (4-20 mA), three alarms, one pulse, MODBUS TCP/IP (VT,VTP only), DCHPOE ONLY*
3AB	Three analog outputs (4-20 mA), three alarms, one pulse, BACnet MS/TP (VT,VTP only), DCH or AC option only *
3ABIP	Three analog outputs (4-20 mA), three alarms, one pulse, BACnet/IP (VT,VTP only), DCHPOE ONLY*

*Includes scaled frequency output

Feature 9: Temperature Options

ST	Standard temperature. Process temperature -330° to 500°F (-200° to 260°C)
HT	High temperature. Process temperature 750°F (400°C)

Feature 10: Pressure Options

P0	No Pressure Sensor
P1	Maximum 30 psia (2 bara), Proof 60 psia (4 bara)
P2	Maximum 100 psia (7 bara), Proof 200 psia (14 bara)
P3	Maximum 300 psia (20 bara), Proof 600 psia (41 bara)
P4	Maximum 500 psia (34 bara), Proof 1000 psia (64 bara)
P5	Maximum 1500 psia (100 bara), Proof 2500 psia (175 bara)

Feature 11: Differential Pressure Transmitter

AZ	Factory supplied Azbil differential pressure transmitter
CX	Customer supplied differential pressure transmitter*

*Customer supplied differential pressure transmitter output must be scaled to factory specifications

Feature 12: Differential Pressure Transmitter Manifold

3M	3-way SST manifold. Ability to equalize high/low side pressures to set the differential pressure transmitter zero
5M	5-way SST manifold. Ability to equalize high/low side pressures to set the differential pressure transmitter zero and the ability to check for equalizing valve leaks
NM	No manifold

Feature 13: Advanced Diagnostics (DP Health Check) - Additional Differential Pressure Transmitters

- Advanced Diagnostics (DP Health Check) requires two additional differential pressure transmitters and a spool piece with an additional pressure tap

ND	No Advanced Diagnostics (DP Health Check)
2AZ	Two additional factory supplied Azbil differential pressure transmitters
2CX	Customer supplied two additional differential pressure transmitters

Feature 14: Advanced Diagnostics (DP Health Check) - Spool Piece with Additional Pressure Tap

- Advanced Diagnostics (DP Health Check) requires two additional differential pressure transmitters and a spool piece with an additional pressure tap

ND	No Advanced Diagnostics (DP Health Check)
FT	Factory supplied spool piece with additional pressure tap
CT	Customer supplied spool piece with additional pressure tap*

*Customer supplied spool piece with pressure tap must be built to factory specifications for proper operation.

Feature 15: Cone Meter Beta Ratio

-Beta Ratio is determined through flow sizing.

По вопросам продаж и поддержки обращайтесь:

Алматы (7273)495-231	Казань (843)206-01-48	Новокузнецк (3843)20-46-81	Смоленск (4812)29-41-54
Архангельск (8182)63-90-72	Калининград (4012)72-03-81	Новосибирск (383)227-86-73	Сочи (862)225-72-31
Астрахань (8512)99-46-04	Калуга (4842)92-23-67	Омск (3812)21-46-40	Ставрополь (8652)20-65-13
Барнаул (3852)73-04-60	Кемерово (3842)65-04-62	Орел (4862)44-53-42	Сургут (3462)77-98-35
Белгород (4722)40-23-64	Киров (8332)68-02-04	Оренбург (3532)37-68-04	Тверь (4822)63-31-35
Брянск (4832)59-03-52	Краснодар (861)203-40-90	Пенза (8412)22-31-16	Томск (3822)98-41-53
Владивосток (423)249-28-31	Красноярск (391)204-63-61	Пермь (342)205-81-47	Тула (4872)74-02-29
Волгоград (844)278-03-48	Курск (4712)77-13-04	Ростов-на-Дону (863)308-18-15	Тюмень (3452)66-21-18
Вологда (8172)26-41-59	Липецк (4742)52-20-81	Рязань (4912)46-61-64	Ульяновск (8422)24-23-59
Воронеж (473)204-51-73	Магнитогорск (3519)55-03-13	Самара (846)206-03-16	Уфа (347)229-48-12
Екатеринбург (343)384-55-89	Москва (495)268-04-70	Санкт-Петербург (812)309-46-40	Хабаровск (4212)92-98-04
Иваново (4932)77-34-06	Мурманск (8152)59-64-93	Саратов (845)249-38-78	Челябинск (351)202-03-61
Ижевск (3412)26-03-58	Набережные Челны (8552)20-53-41	Севастополь (8692)22-31-93	Череповец (8202)49-02-64
Иркутск (395)279-98-46	Нижний Новгород (831)429-08-12	Симферополь (3652)67-13-56	Ярославль (4852)69-52-93
Россия (495)268-04-70	Киргизия (996)312-96-26-47	Казахстан (7172)727-132	